

ITEM NO	COLOR	LENGTH
DVIAF-VGA-1MM	BLACK	1000±30mm
DVIAF-VGA-2MM	BLACK	2000±30mm
DVIAF-VGA-3MM	BLACK	3000±50mm
DVIAF-VGA-5MM	BLACK	5000±50mm

- NOTE: Wire Mark: E314459 兄 AWM 20276 80°C 30V VW-1
- CABLE: UL20276,AL/MY+B-FOIL,[(28AWG*3COAX+#28*1P+#28*5C),BLACK COLOR,OD=7.0mm,PVC JACKET
 - LENGTH: L.
 - CONNECTORS: DVI(18+5)M*1(BLACK INSULATOR)--HDB15M*1(BLUE INSULATOR)(SHELL GOLD PLATED).
 - MOLD: ASS'Y TYPE.
 - SCREW: #4*40 INCH SCREW*2PCS,#4*40 INCH SCREW*2PCS(SHELL NICKEL). 头镀金, 螺丝镀镍.
 - CONTACTS:

DVI(18+5)P	6	7	C1	C5	C2	C5	C3	C5	8	14	16	15	C4	64
HD15M	15	12	1	6+7+8	2	6+7+8	3	6+7+8	14	9	9	5+10	13	64
	PAIR		RC	RG	CC	CC	BC	BC	28AWG				SHELL	

- OPEN/SHORT TEST: 100% TEST.
- INSULATION: COND: 5Ω MAX, HIPLT: 300V, INS: 10MΩ MIN
- ALL MUST BE ROHS COMPLIANT.

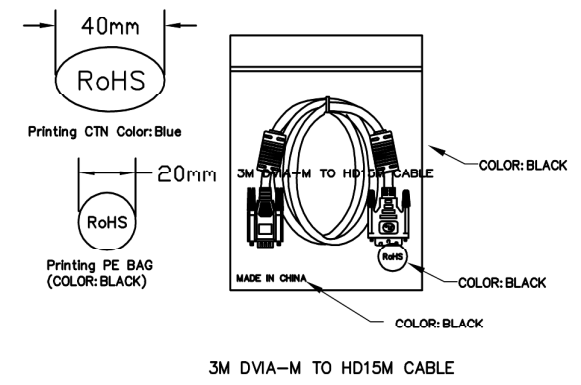

COMPANY	MRP		ITEM NO.	NO		B			SCALE	
REVISION	DATE	DISCRIPTION	DRAWN BY				DVIAF-VGA-xxMM		UNIT(mm)	
REV.A/0	2015.06.11		DESIGNED BY					DRAWING NO.		
			APPROVAL BY							